

## **MEMROCK TECHNOLOGIES BARCODE DECODER IC CHIP**

This barcode decoder IC chip is designed to meet the needs for low cost, small space, and most importantly strong decoding algorithm to increase the performance of the product especially in the environment where the barcodes are printed with poor quality. Other interesting features such as standby mode, and wide operating voltages and temperature.

Part Number	ADC2980S      5V Surface mount ADC2980S-3    3.3V Surface mount  Through hole (Dip) package is available for prototype only
Symbologies	Code39, interleaved 2 of 5, Codabar, Code93, Code128, UPC A, UPC E0 & E1, EAN 8 & 13 with 2 or 5-digit supplements
Maximum Scanning Speed	140 inches per second @ narrow element width of 0.0075 inch.
Operating Temperature.	-40° to 85°C

### **General Specifications.**

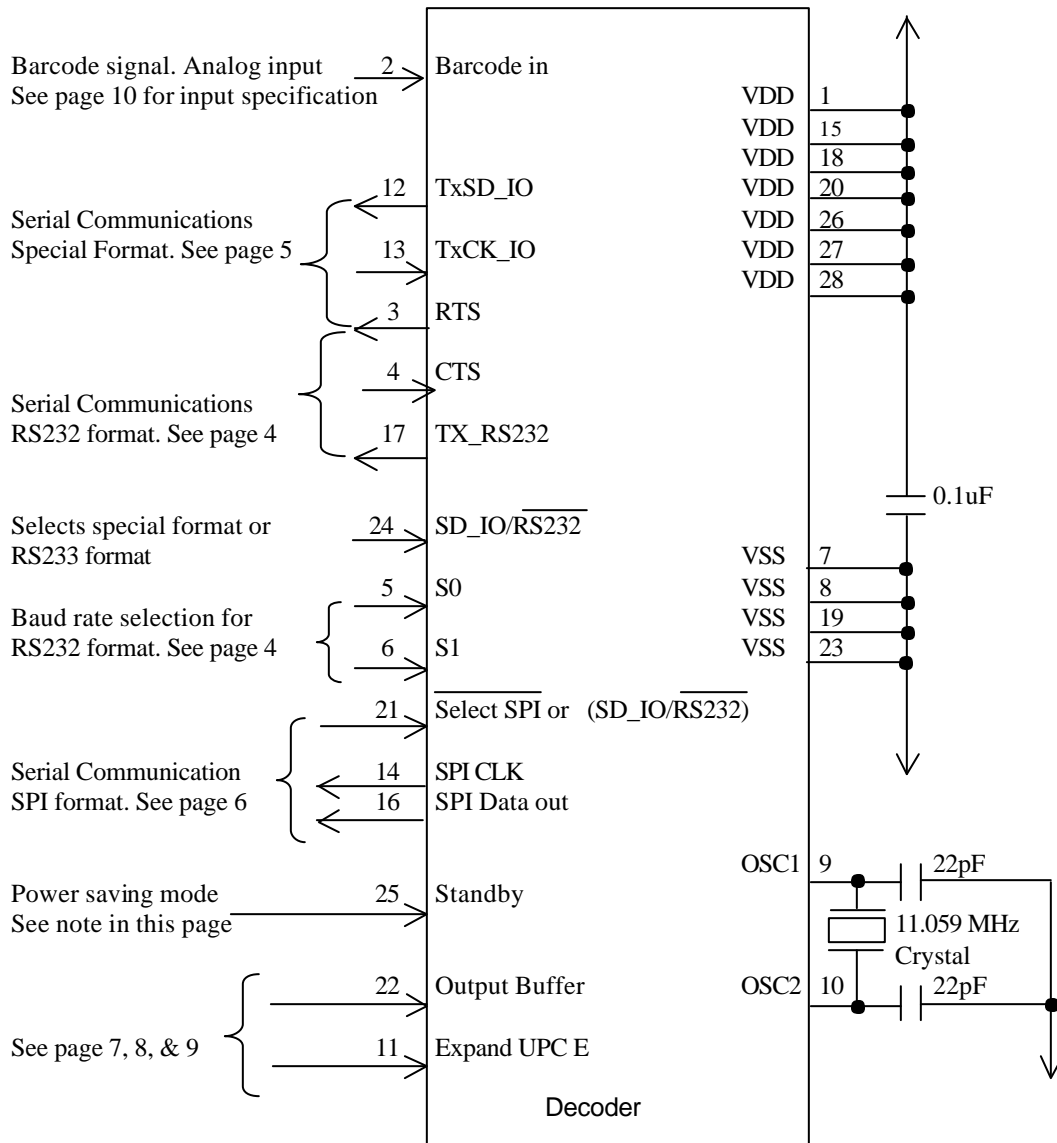
- . Operating voltage range (VDD) part no. ADC2980S:      4.2V to 5.5V
- . Operating voltage range (VDD) part no. ADC2980S-3:    2.0V to 3.6V
  
- . Supply current @ VDD: 5mA
- . Input low voltage    Min: Vss,    Max: 0.15VDD
- . Input high voltage    Min: 0.8VDD,    Max: VDD
- . Output low voltage    Max: 0.6V
- . Output high voltage    Min: VDD – 0.7
- Pin 2 is analog input. See page 10 for analog circuits and specification.
- . Operating Speed: 11.059 MHz.

### **Absolute Maximum Rating**

Ambient temperature under bias	-40° to 125°C
Storage temperature	-65° to 150°C
Voltage on any pin with respect to VSS	-0.3V to (VDD + 0.3V)
Maximum output current sunk by any I/O pin	25mA
Maximum output current sourced by any I/O pin	25mA

For Sales/Tech support or other decoders, please call (714) 906-1865 or visit [Memrock Technologies](http://www.memrock.com)

## Pin-outs Diagram

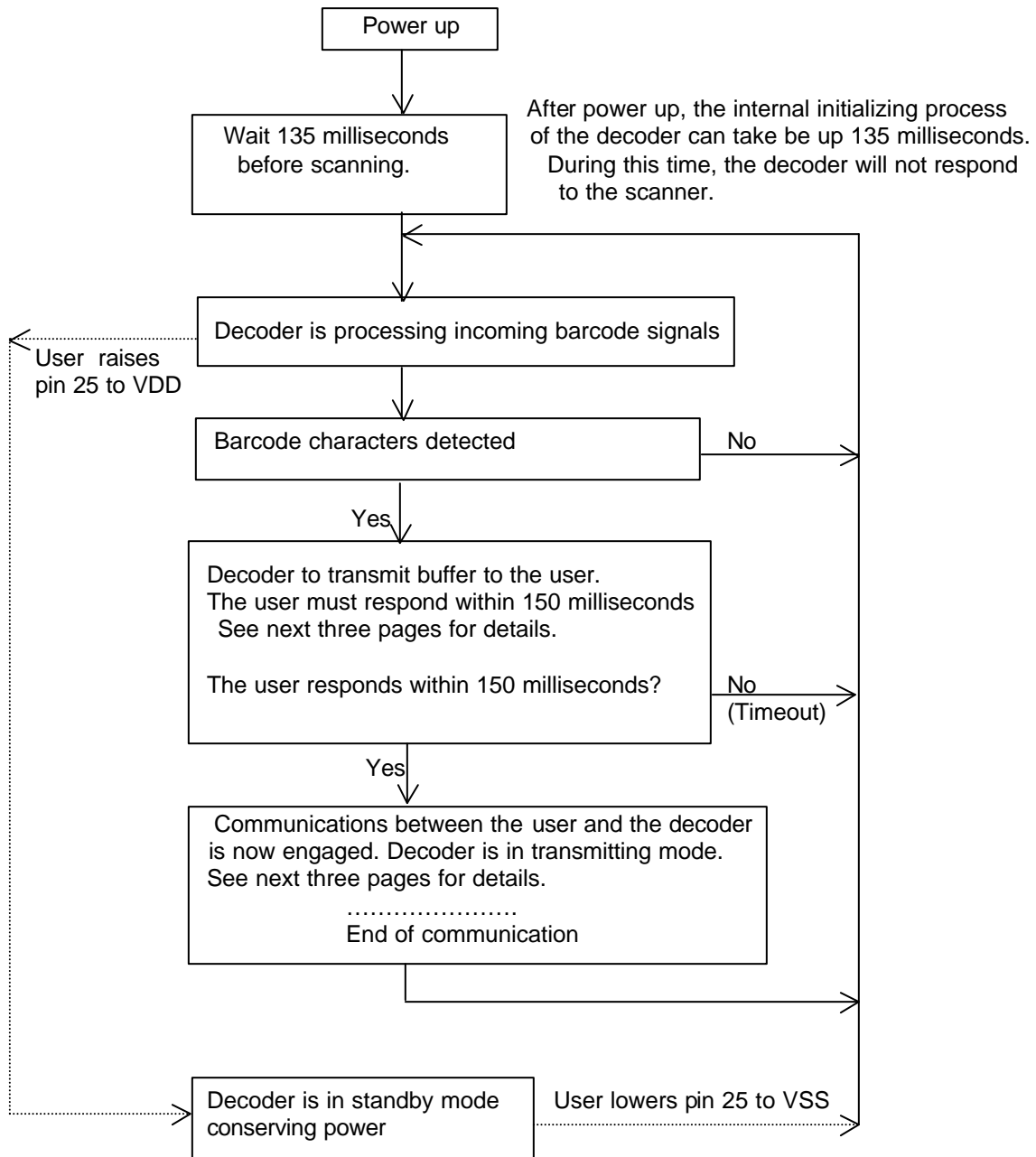


### Note: Decoder in Standby Mode.

In this mode, if the user raises pin 25 of the decoder to VDD, then the decoder enters a standby mode to conserve power. If the user lowers pin 25 of the decoder to VSS, then the decoder will exit the standby mode and starts in normal mode after 10 milliseconds.

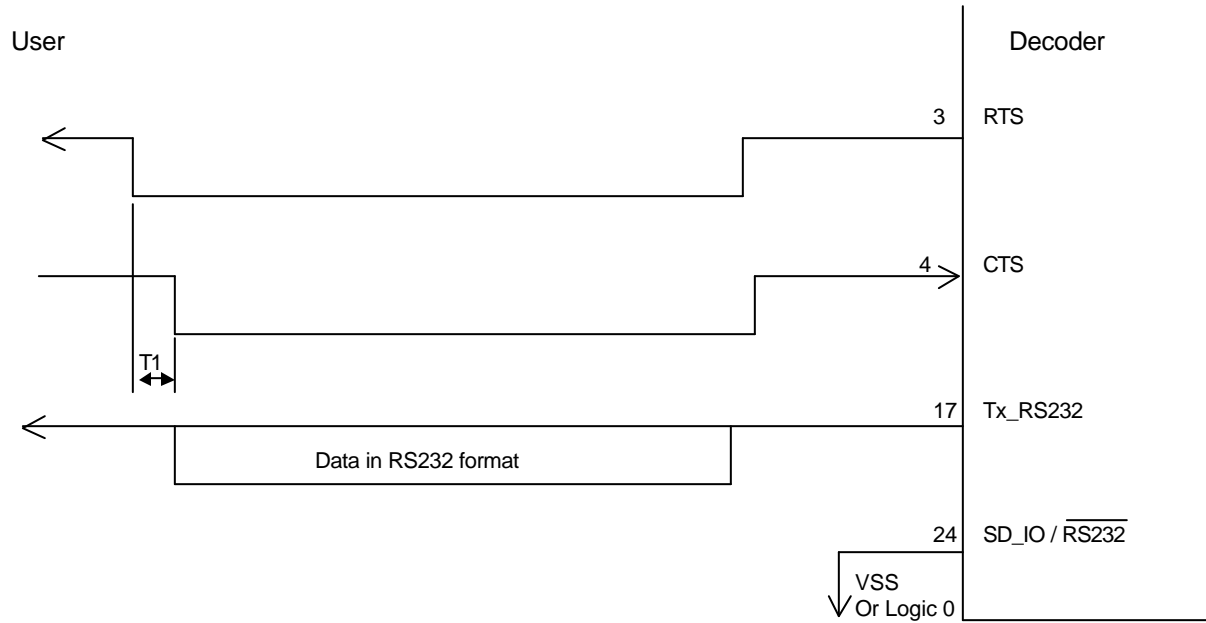
In this standby mode, the decoder conserves power by reducing the supply current to less than 3.0uA.

**Decoder Process.**



For Sales/Tech support or other decoders, please call (714) 906-1865 or visit [Memrock Technologies](http://www.memrock.com)

**Decoder in data transmitting mode  
RS232 Format**



Decoders lowers RTS pin, and waits for CTS to be lowered.

After CTS is being lowered, the decoder will start to transmit. The decoder will raise RTS pin after transmission of data is completed.

$T_1$  is 0 second min. 150 milliseconds Max. If max is exceeded without lowering CTS pin, then communications is terminated. RTS and CTS can be tied together.

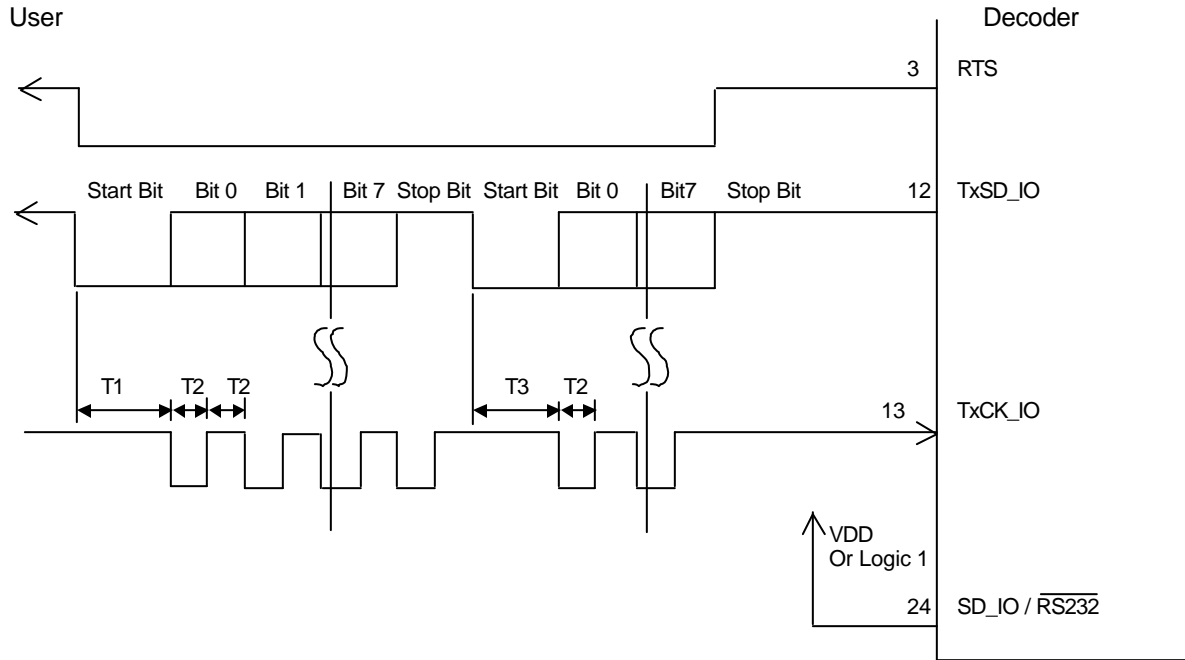
**Communication settings**

S0	S1	Baud rate (bits per second)
0	0	9600
0	1	19200
-	-	-
1	0	1200
1	1	2400
8 bit data, 1 stop bit.		

S0=pin5, S1=pin6, logic 0=VSS, Logic 1=VDD.

**Note:** If the output of the decoder is to be connected to external device (PC for example), then a voltage level converter (RS232 or RS485 transceiver) will be required.

**Decoder in data transmitting mode  
Special Format**



**Decoder in Transmitting Mode, User in Receiving Mode**

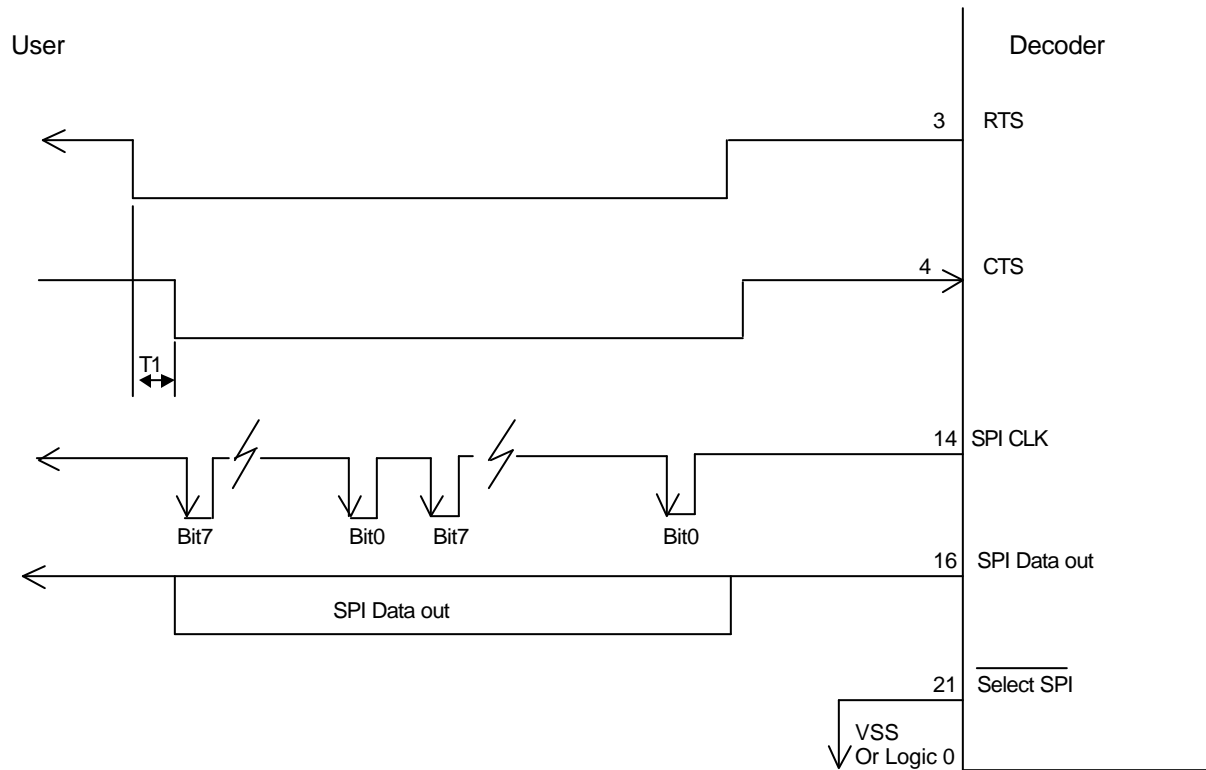
If the decoder has valid buffer/barcode characters to transmit then the decoder will enter this mode. In this mode, the decoder lowers pin 3 and pin 12 to initiate start bit. The decoder then waits for pin 13 to be lowered by the user.

After the user lowers pin 13 of the decoder, the decoder will then output a valid bit. The user can read this valid bit after waiting  $T_2$  seconds and put pin 13 of the decoder to high state (logic 1) for  $T_2$  seconds. This process repeats until the stop bit.  $T_2$  can range from 12 microseconds to 26 milliseconds.

If no response from the user within 26 milliseconds, then the decoder will not wait further, and the communications will terminate.

$T_1$  cannot be greater than 150 milliseconds;  $T_3$  cannot be greater than 26 milliseconds

**Decoder in data transmitting mode  
SPI Communications, decoder in Master Mode.**



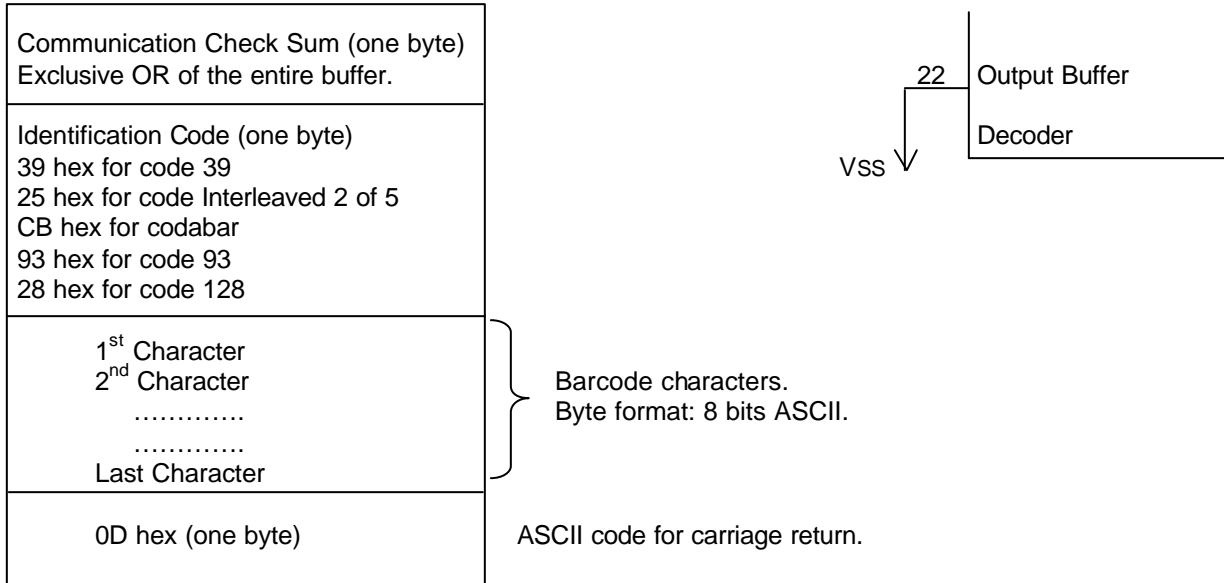
If pin 21 is connected to Vss, then only SPI Communications is enabled. The RS232 or Special format will be disabled regardless of PIN 24 status.

In the SPI mode, the idle state of the clock is high, and the valid output bit is on falling edge of clock. The clock frequency is 172.8 KHz. The decoder is in transmitting/master mode, and the neighboring processor is in receiving/slave mode.

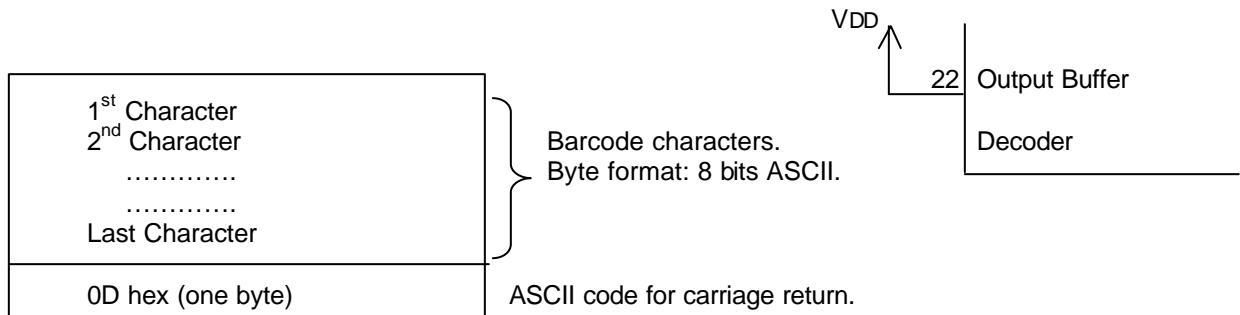
In this SPI mode, the decoders lowers RTS pin, and waits for CTS to be lowered.

After CTS is being lowered, the decoder will start to transmit. The decoder will raise RTS pin after transmission of data is completed.

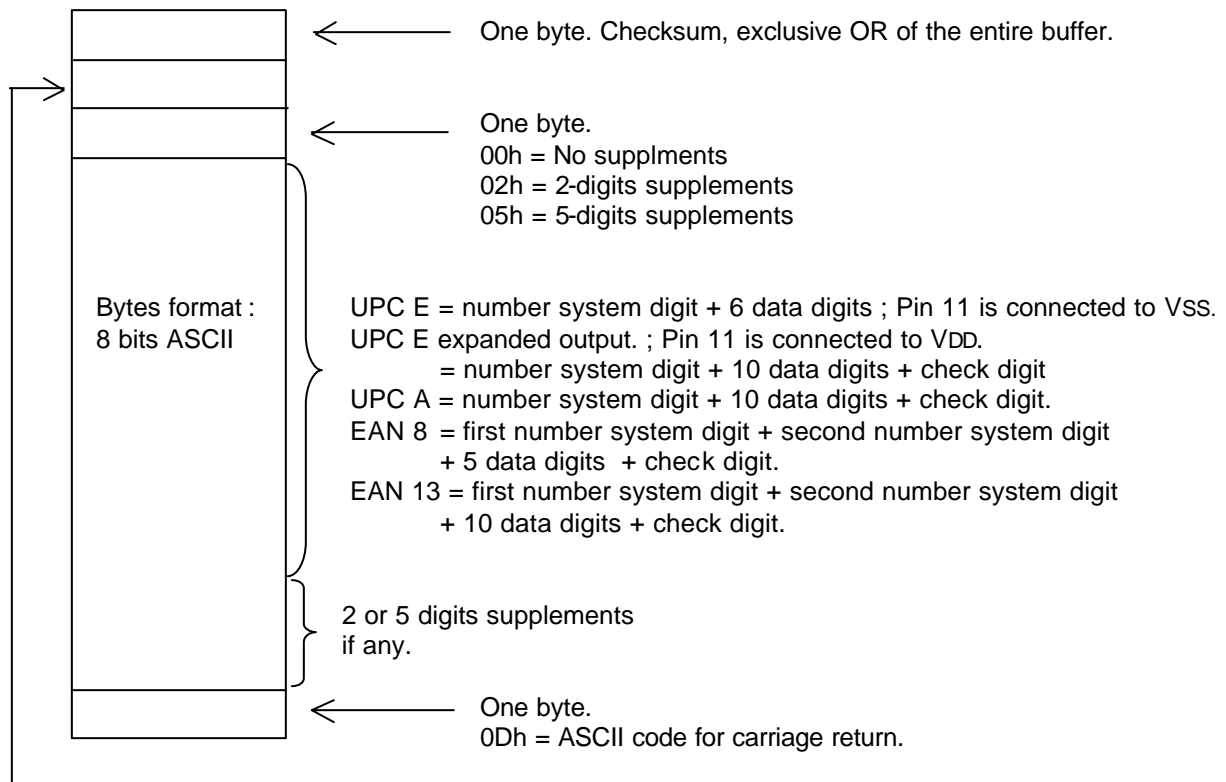
T1 is 0 second min. 150 milliseconds Max. If max is exceeded without lowering CTS pin, then communications is terminated. RTS and CTS can be tied together.



**Figure 1:** Structure of transmitted buffer from decoder to the user for Code 39, I25, Codabar, Code93, and Code128. See page 8 & 9 for UPC/EAN. For this type of output buffer, connect Pin22 of decoder to VSS.

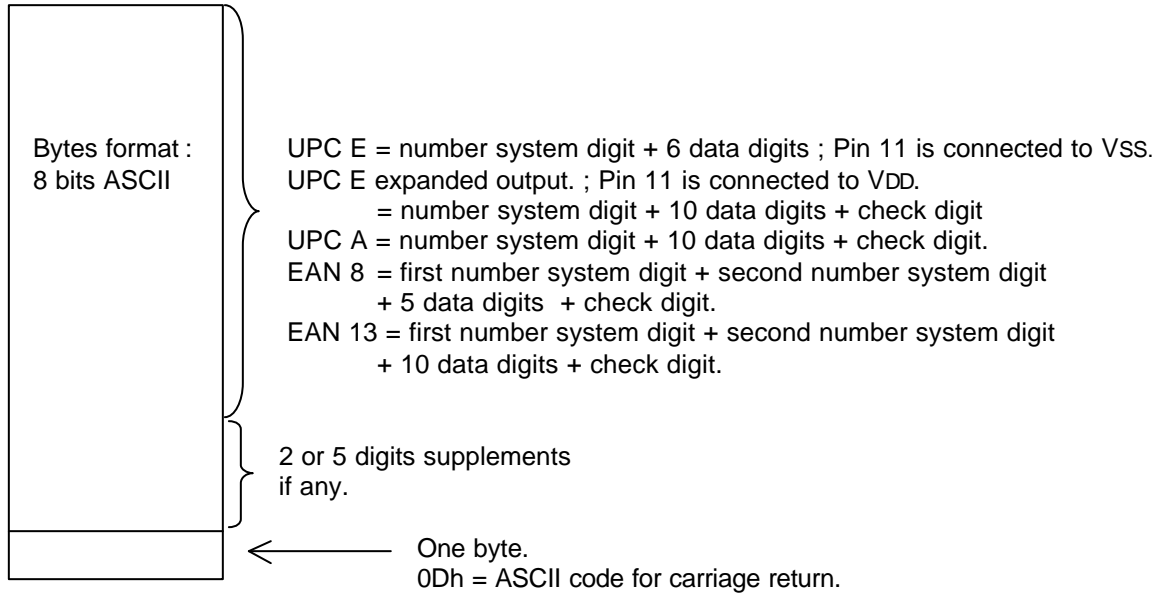


**Figure 2:** Structure of transmitted buffer from decoder to the user for Code 39, I25, Codabar, Code93, and Code128. See page 8 & 9 for UPC/EAN. For this type of output buffer, connect Pin22 of decoder to VDD.



One byte symbology identifier	Symbology
10h	UPC E
20h	EAN 8
30h	UPC A
40h	EAN 13

**Figure 3:** Structure of transmitted buffer for UPC/EAN from decoder to the user.  
For this type of output buffer, connect Pin22 of decoder to VSS.



**Figure 4:** Structure of transmitted buffer for UPC/EAN from decoder to the user.  
For this type of output buffer, connect Pin22 of decoder to VDD.

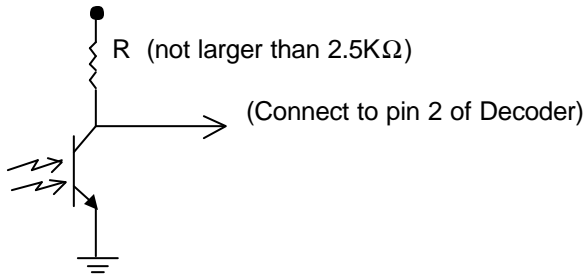
**Analog input specification and application examples.**

**Input Specification**

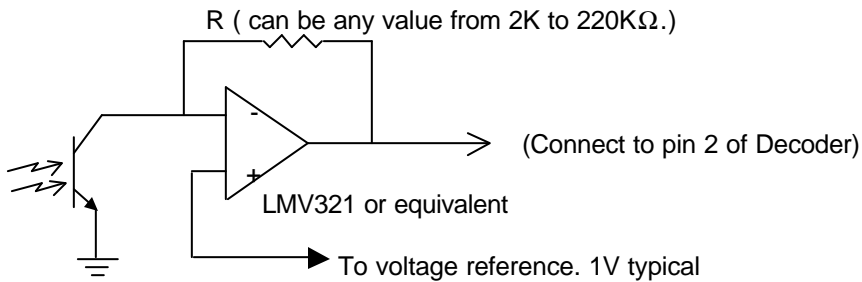
Minimum peak to peak: is 0.5V.

The barcode signal can be shifted by DC level as long as the peak to peak is within device operating voltage (VSS to VDD)

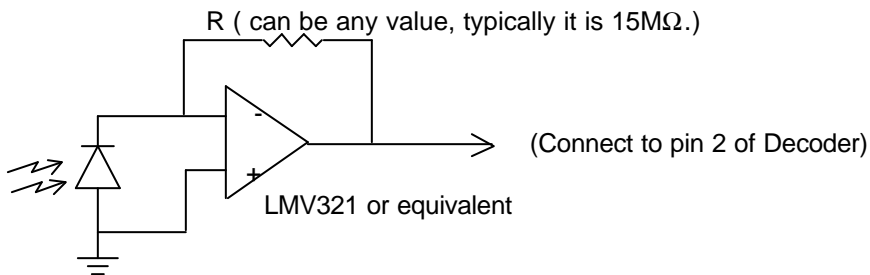
Analog source of type A (Phototransistor without amplifier).



Analog source of type B (Phototransistor with amplifier).

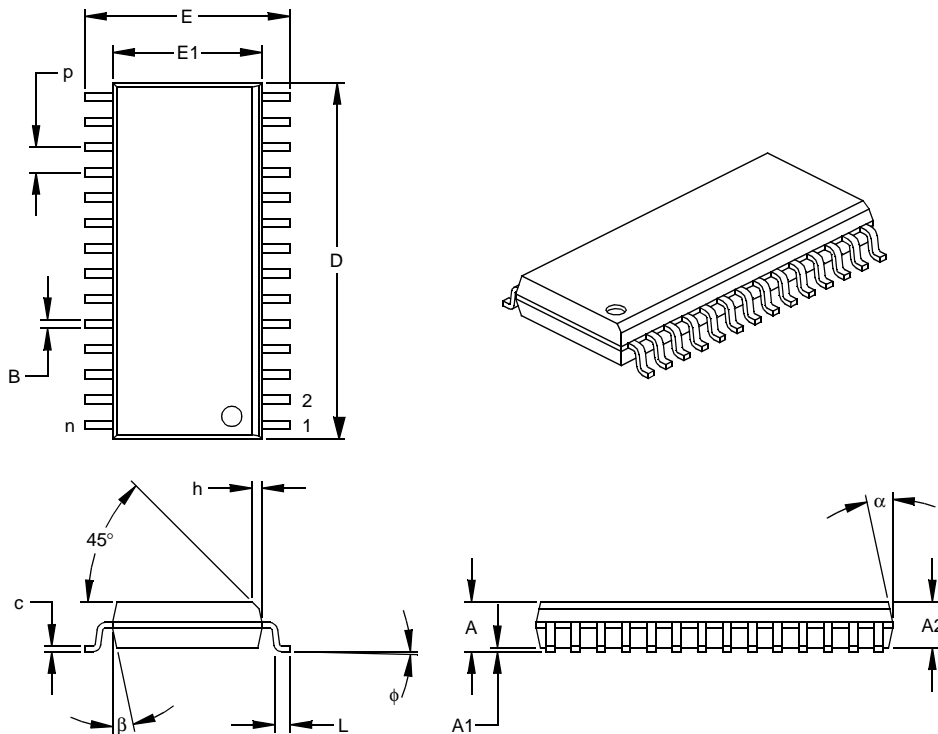


Analog source of type C (Photodiode with amplifier).



For Sales/Tech support or other decoders, please call (714) 906-1865 or visit [Memrock Technologies](http://www.memrock.com)

## 28-Lead Plastic Small Outline (SO) – Wide, 300 mil (SOIC)



Dimension Limits	Units	INCHES*			MILLIMETERS		
		MIN	NOM	MAX	MIN	NOM	MAX
Number of Pins	n		28			28	
Pitch	p		.050			1.27	
Overall Height	A	.093	.099	.104	2.36	2.50	2.64
Molded Package Thickness	A2	.088	.091	.094	2.24	2.31	2.39
Standoff §	A1	.004	.008	.012	0.10	0.20	0.30
Overall Width	E	.394	.407	.420	10.01	10.34	10.67
Molded Package Width	E1	.288	.295	.299	7.32	7.49	7.59
Overall Length	D	.695	.704	.712	17.65	17.87	18.08
Chamfer Distance	h	.010	.020	.029	0.25	0.50	0.74
Foot Length	L	.016	.033	.050	0.41	0.84	1.27
Foot Angle Top	φ	0	4	8	0	4	8
Lead Thickness	c	.009	.011	.013	0.23	0.28	0.33
Lead Width	B	.014	.017	.020	0.36	0.42	0.51
Mold Draft Angle Top	α	0	12	15	0	12	15
Mold Draft Angle Bottom	β	0	12	15	0	12	15

\* Controlling Parameter

§ Significant Characteristic

**Notes:**

Dimensions D and E1 do not include mold flash or protrusions. Mold flash or protrusions shall not exceed .010" (0.254mm) per side.

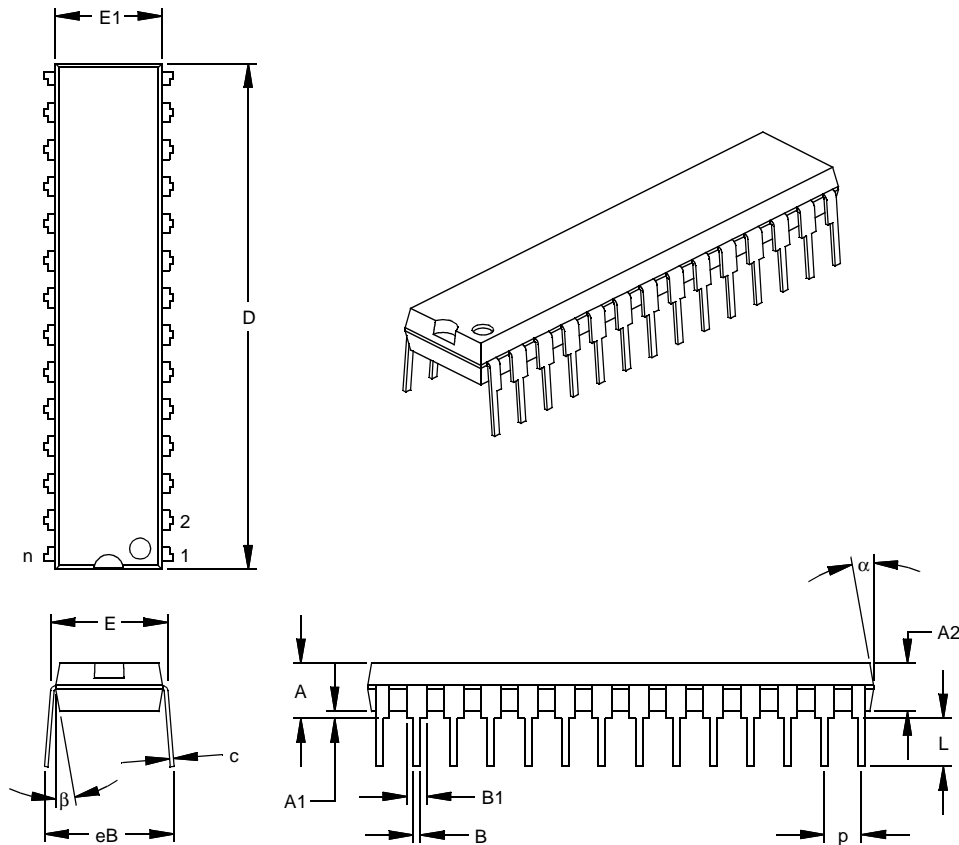
JEDEC Equivalent: MS-013

Drawing No. C04-052

## 23.2 Package Details

The following sections give the technical details of the packages.

### 28-Lead Skinny Plastic Dual In-line (SP) – 300 mil (PDIP)



Units		INCHES*			MILLIMETERS		
Dimension Limits		MIN	NOM	MAX	MIN	NOM	MAX
Number of Pins	n		28			28	
Pitch	P		.100			2.54	
Top to Seating Plane	A	.140	.150	.160	3.56	3.81	4.06
Molded Package Thickness	A2	.125	.130	.135	3.18	3.30	3.43
Base to Seating Plane	A1	.015			0.38		
Shoulder to Shoulder Width	E	.300	.310	.325	7.62	7.87	8.26
Molded Package Width	E1	.275	.285	.295	6.99	7.24	7.49
Overall Length	D	1.345	1.365	1.385	34.16	34.67	35.18
Tip to Seating Plane	L	.125	.130	.135	3.18	3.30	3.43
Lead Thickness	c	.008	.012	.015	0.20	0.29	0.38
Upper Lead Width	B1	.040	.053	.065	1.02	1.33	1.65
Lower Lead Width	B	.016	.019	.022	0.41	0.48	0.56
Overall Row Spacing	§ eB	.320	.350	.430	8.13	8.89	10.92
Mold Draft Angle Top	α	5	10	15	5	10	15
Mold Draft Angle Bottom	β	5	10	15	5	10	15

\* Controlling Parameter

§ Significant Characteristic

Notes:

Dimension D and E1 do not include mold flash or protrusions. Mold flash or protrusions shall not exceed .010" (0.254mm) per side.

JEDEC Equivalent: MO-095

Drawing No. C04-070